

# TAP A NEW ENERGY CLASS



# FELIX SG

## Inseln

Kuehinsel mit Aggregat. Geeignet fuer jede Verkaufsoberflaeche



# FELIX SG TN

## FELIX SG - Inseln

### Stromversorgung

Steckerfertig

### Klimaklassen

3 M1

3 M2



### Ausstellungskategorien



Delikatessen



Essen zum Mitnehmen



Fertiggerichte und Salate



Impulskauf



Milchprodukte, Milche, Käse



Verpackter Fleisch



Würst

### Standard Ausstattungen

Ultrapanorama Glas  
Elektronische Steuerung  
Kältemittel R290  
Umluftkühlung

### Zubehöre

Holzverpackung  
Rollen  
Satz Bodengitter, lackiert  
Trennungen

### Verfügbare Abmessungen

|                       |                     |
|-----------------------|---------------------|
|                       | 1320;1470;1920;2520 |
| äußere Tiefe (mm)     | 1003                |
| Höhe mit S.teile (mm) | 945                 |

# TECHNISCHE ZEICHNUNGEN

---

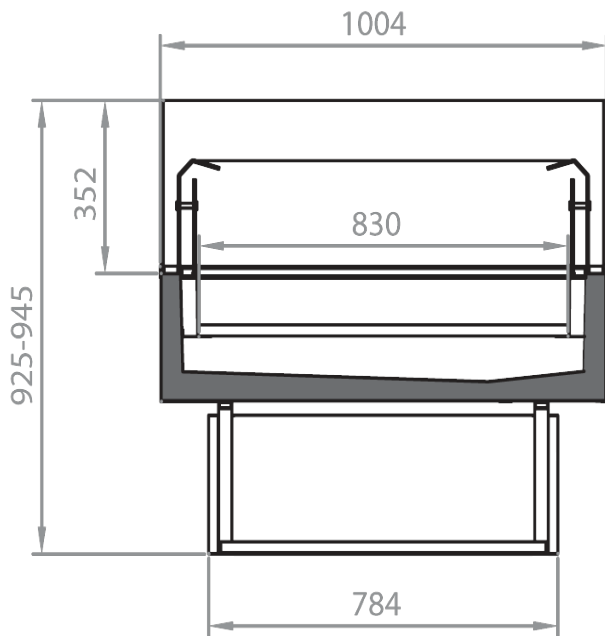

FELIX SG

# FELIX SG TN

## FELIX SG - Inseln

### Stromversorgung

Steckerfertig

### Klimaklassen

3 M1

3 M2



### Erhältliche Farben

1021

6032

3020

7037

9010

5007

7047

9011

7024

2004

9006

### Ausstellungskategorien



Delikatessen



Essen zum  
Mitnehmen



Fertiggerichte und  
Salate



Impulskauf



Milchprodukte,  
Milche, Käse



Verpackter Fleisch



Würst

### Standard Ausstattungen

Ultrapanorama Glas  
Elektronische Steuerung  
Kältemittel R290  
Umluftkühlung

### Zubehöre

Holzverpackung  
Rollen  
Satz Bodengitter, lackiert  
Trennungen

### Verfügbare Abmessungen

|                       |                     |
|-----------------------|---------------------|
|                       | 1320;1470;1920;2520 |
| äußere Tiefe (mm)     | 1003                |
| Höhe mit S.teile (mm) | 945                 |

# EINIGE FOTOS

---

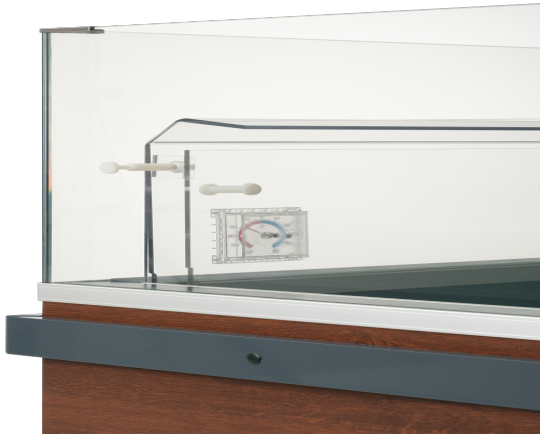

# TECHNISCHE ZEICHNUNGEN

---

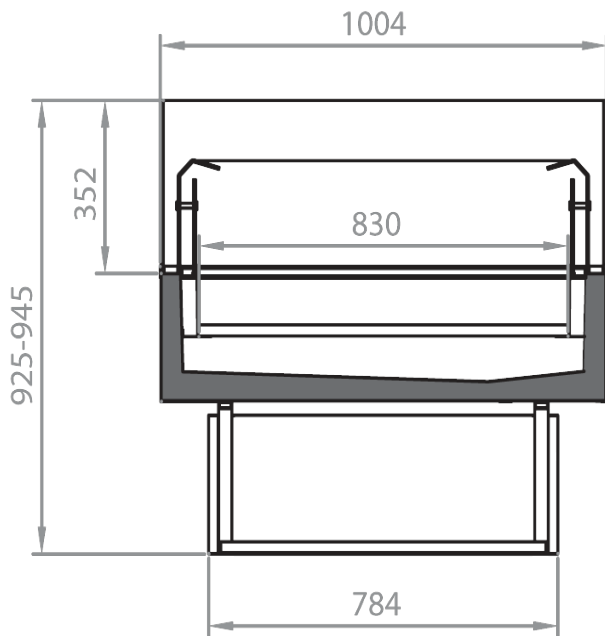

FELIX SG



**Pastorfrigor S.p.A.**

Reg. Gabannone, 4 Z.I. · 15033 Terruggia (AL) · Italy  
Tel. +39 0142 433 711 · Fax +39 0142 433 701 · [info@pastorfrigor.it](mailto:info@pastorfrigor.it)  
P.IVA IT00578270068 | REA AL-00578270068  
[www.pastorfrigor.it](http://www.pastorfrigor.it)