

# TAP A NEW ENERGY CLASS



# KALIFORNIA Q

## Wandkühlregale

Schmales Wandkuehlregal mit externem Kaeltanschluss. Geeignet fuer kleine Verkaufsoberflaeche. Grosse Ladekapazitaet trotz schmaler Tiefen. Eckige Form.



# KALIFORNIA Q

## Kalifornia Q - Wandkühlregale

### Stromversorgung

Ohne Kompressor

### Klimaklassen

3 H

3 M1

3 M2



### Erhältliche Farben

1021

6032

3020

7037

9010

5007

7047

9011

7024

2004

9006

### Ausstellungskategorien



Biere & Weine



Delikatessen



Fertiggerichte und Salate



Gekühlte Getränke



Milchprodukte, Milche, Käse



Obst und Gemüse



Snacks / Sandwiches



Verpackter Fleisch



Würst

### Standard Ausstattungen

5 reihig Regalen mit Preisschienen an Regalen und Bodenwanne  
Digital Thermometer  
Elektronische Steuerung  
Möbelfrontbeleuchtung T5  
Thermostatisches Expansionsventil  
Umluftkühlung

### Zubehöre

CO2-Kühlsystem  
E-Ventil mit Spule  
Glastrennwand feststehend und mobil  
LED-Beleuchtung  
Manuelle oder E-nachtrollo  
Mögliche interne und externe RAL-Farben  
Regalbeleuchtung T5/LED

# EINIGE FOTOS

---



# TECHNISCHE ZEICHNUNGEN

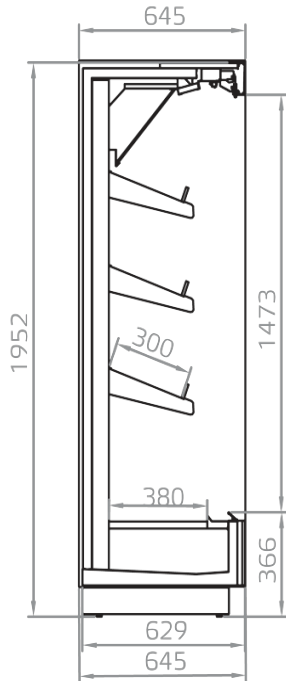

KALIFORNIA Q 300/1950 H

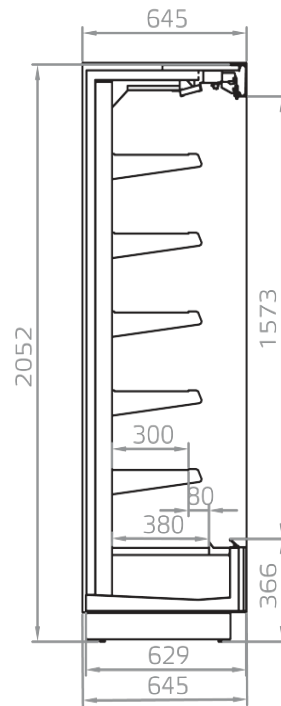

KALIFORNIA Q 300/2050 M1,M2

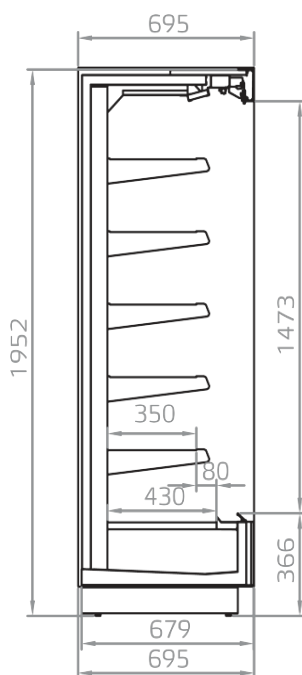

KALIFORNIA Q 350/1950 M1,M2

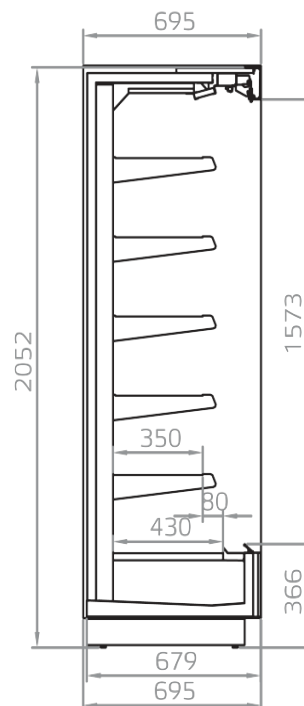

KALIFORNIA Q 350/2050 M1,M2

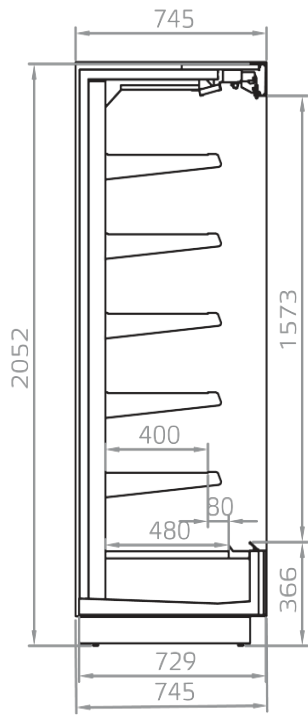

KALIFORNIA Q 400/2050 M1,M2

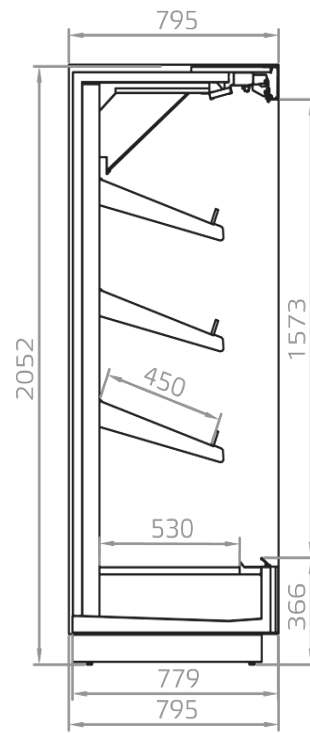

KALIFORNIA Q 450/2050 H

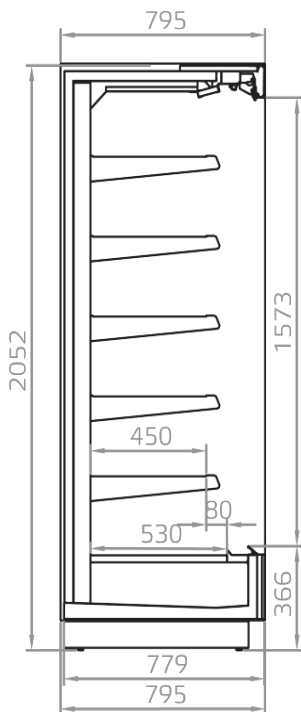

KALIFORNIA Q 450/2050 M1,M2



**Pastorfrigor S.p.A.**

Reg. Gabannone, 4 Z.I. · 15033 Terruggia (AL) · Italy  
Tel. +39 0142 433 711 · Fax +39 0142 433 701 · [info@pastorfrigor.it](mailto:info@pastorfrigor.it)  
P.IVA IT00578270068 | REA AL-00578270068  
[www.pastorfrigor.it](http://www.pastorfrigor.it)