

TAP A NEW ENERGY CLASS



VULCANO

Islands

With the Vulcano plug-in island, Pastorfrigor range is implemented with another valid element that with simplicity, minimum space required and large exhibition area, allows a complete view of the products. The module consists of two display decks which are divided by a transparent intermediate separator, which leaves field of view on both sides. Available with built-in unit R290: 1250mm , 1875 mm and headcase



VULCANO

VULCANO - Islands

Power supply

Plug in

Climatic classes

3 M2



Exhibition categories



Dairy, milk, cheese



Delicatessen



Food to go



Impulse



Ready meals and salads



Sausages & salami



Snacks / Sandwiches

Standard features

1 shelf with priceholder
R290 gas
Top lighting LED
White display plates

Accessories

Dividers
LED lighting
Stainless steel bumper
Stainless Steel display decks

Available dimensions

Length without side walls 1250,1875
(mm)

CROSS SECTIONS

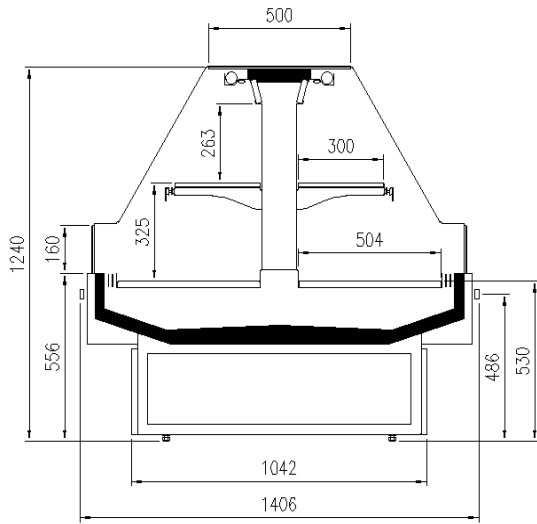

VULCANO

VULCANO

VULCANO - Islands

Power supply

Plug in

Climatic classes

3 M2



Available colours

1015

1021

2011

3002

3020

5005

5012

6018

7035

7037

9006

9010

9011

Exhibition categories



Dairy, milk, cheese



Delicatessen



Food to go



Impulse



Ready meals and
salads



Sausages & salami



Snacks / Sandwiches

Standard features

1 shelf with priceholder
R290 gas
Top lighting LED
White display plates

Accessories

Dividers
LED lighting
Stainless steel bumper
Stainless Steel display decks

Available dimensions

Length without side walls 1250,1875
(mm)

CROSS SECTIONS

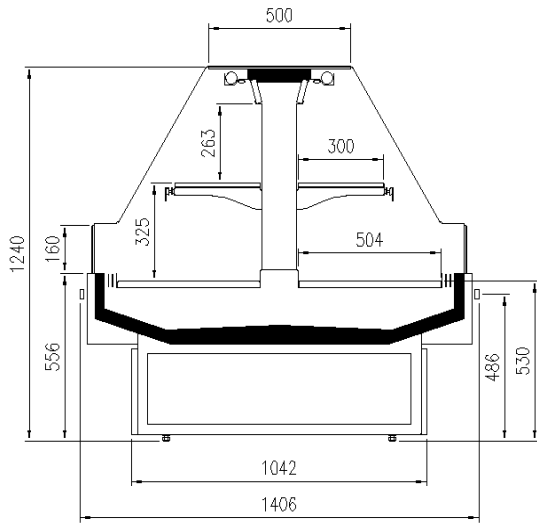

VULCANO



Pastorfrigor S.p.A.

Reg. Gabannone, 4 Z.I. · 15033 Terruggia (AL) · Italy
Tel. +39 0142 433 711 · Fax +39 0142 433 701 · info@pastorfrigor.it
P.IVA IT00578270068 | REA AL-00578270068
www.pastorfrigor.it