

TAP A NEW ENERGY CLASS



PANAREA NG

Islands

Impulse island to maximise sales. Spot merchandising at its best with mobile display for fresh meat promotions. Energy efficient with proven reliability makes this a very sound impulse chiller.



PANAREA NG

PANAREA NG - Islands

Power supply

Plug in

Remote

Climatic classes

3 M1



Available colours

1015

1021

2011

3002

3020

5005

5012

6018

7035

7037

9006

9010

9011

Exhibition categories



Dairy, milk, cheese



Delicatessen



Food to go



Impulse



Packed meat



Ready meals and
salads



Snacks / Sandwiches

Standard features

Castors
Fan assisted cooling
Glazed endwalls
Hot gas evaporating system
R290 gas
Stainless steel bumper
White display plates

Accessories

Dividers
Night covers
Wooden Crate

Available dimensions

External depth (mm) 1120
Height (mm) 900
Length with side walls (mm) 1058 - 1370
Length without side walls (mm) 937 - 1250
Thickness side walls (mm) 120

A SELECTION FROM OUR INSTALLATION



CROSS SECTIONS

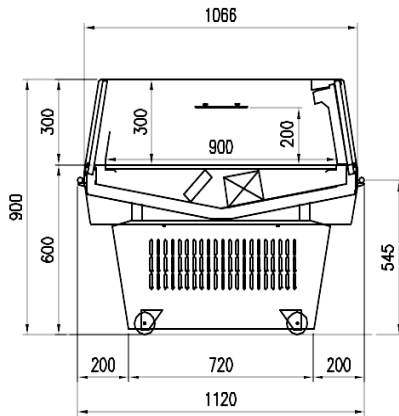

NG



Pastorfrigor S.p.A.

Reg. Gabannone, 4 Z.I. · 15033 Terruggia (AL) · Italy
Tel. +39 0142 433 711 · Fax +39 0142 433 701 · info@pastorfrigor.it
P.IVA IT00578270068 | REA AL-00578270068
www.pastorfrigor.it