

TAP A NEW ENERGY CLASS



Islands

Dependable wall sited frozen food display. High capacity low temperature with in-built flexibility so you can merchandise along the wall or in an island line up that makes this the most versatile choice for your frozen food offer.



CAPRI BT

CAPRI - Islands

Power supply

Remote

Climatic classes

3 L1



Available colours

1015

1021

2011

3002

3020

5005

5012

6018

7035

7037

9006

9010

9011

Exhibition categories



Frozen food

Standard features

Automatic defrost
Draining kit
Expansion valve
Fan assisted cooling
Grey ABS bumper
Remote cabinet, multiplexable linear and corner modules
Terminal board
White display plates

Accessories

CO2 refrigeration system
Control board Master and Slave
Electronic valve
Grid dividers
LED lighting
Manual night blind
Night covers
Sliding lids
Stainless steel bumper
Ultrapanoramic glasses
Wooden Crate

Available dimensions

External depth (mm) 1079
Height (mm) 930
Length without side walls 1875 - 2500 - 3750 (mm)

A SELECTION FROM OUR INSTALLATION



CROSS SECTIONS

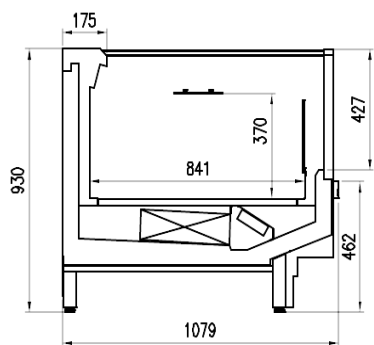

HG



Pastorfrigor S.p.A.

Reg. Gabannone, 4 Z.I. · 15033 Terruggia (AL) · Italy
Tel. +39 0142 433 711 · Fax +39 0142 433 701 · info@pastorfrigor.it
P.IVA IT00578270068 | REA AL-00578270068
www.pastorfrigor.it