

TAP A NEW ENERGY CLASS



LINDA

Counters

Flexible curved glass counter for Patisserie. Sweet performance and flexible design for cakes and pastres the Linda features many configrable options that makes it an all round performer.



LINDA V PLUG IN

LINDA - Counters

Power supply

Plug in

Climatic classes

3 H



Available colours

1021

6032

3020

7037

9010

5007

7047

9011

7024

2004

9006

Exhibition categories



Cakes and baked
delicacies



Dry pastries and
bread

Standard features

- 3 shelves with priceholders
- Available with gas R452 A
- Digital Thermometer
- Fan assisted cooling
- Glass shelves
- Glazed endwalls included
- Plug-in cabinet, not multiplexable linear modules

Accessories

- Internal and external RAL colours
- LED lighting
- Wooden Crate

CROSS SECTIONS

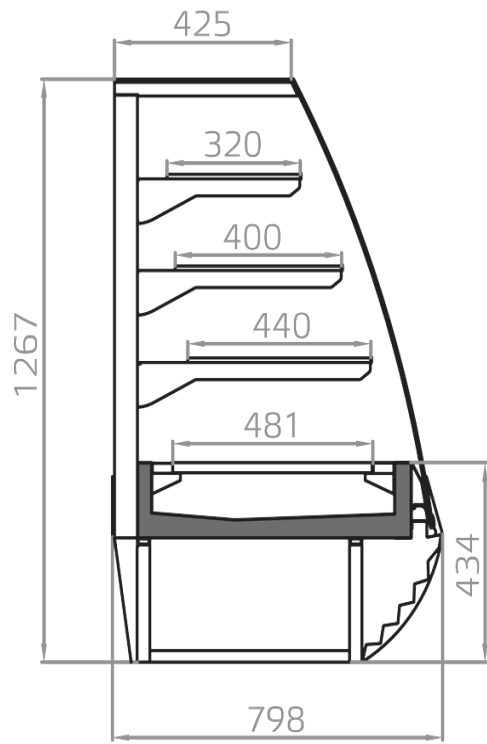

LINDA V



Pastorfrigor S.p.A.

Reg. Gabannone, 4 Z.I. · 15033 Terruggia (AL) · Italy
Tel. +39 0142 433 711 · Fax +39 0142 433 701 · info@pastorfrigor.it
P.IVA IT00578270068 | REA AL-00578270068
www.pastorfrigor.it