

# TAP A NEW ENERGY CLASS



# FELIX SG

## Islands

Effective impulse presenter. Impulse plug-in to lift your sales anywhere in store. Versatility and mobility equals profitability for your promotional frozen or chilled sales.



# FELIX SG TN

## FELIX SG - Islands

### Power supply

Plug in

### Climatic classes

3 M1

3 M2



### Available colours

1021

6032

3020

7037

9010

5007

7047

9011

7024

2004

9006

### Exhibition categories



Dairy, milk, cheese



Delicatessen



Food to go



Impulse



Packed meat



Ready meals and  
salads



Sausages & salami

### Standard features

Electronic control  
Fan assisted cooling  
R290 gas  
Ultrapanoramic glasses

### Accessories

Base Grids  
Castors  
Dividers  
Wooden Crate

### Available dimensions

External depth (mm) 1003  
Height (mm) 945  
Length with side walls (mm) 1320;1470;1920;2520

# A SELECTION FROM OUR INSTALLATION

---

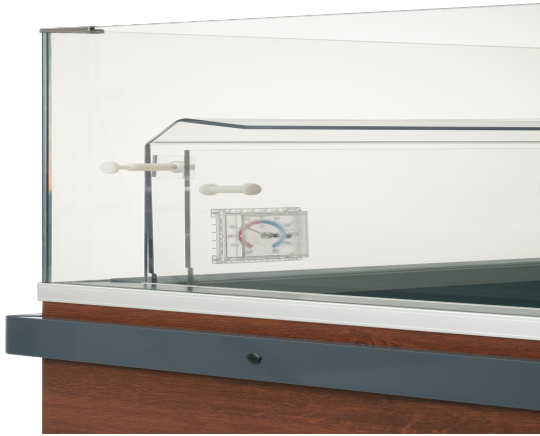

# CROSS SECTIONS

---

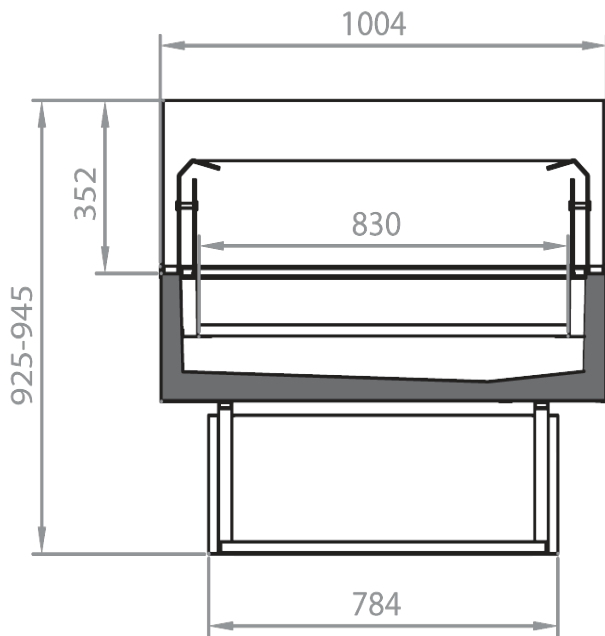

FELIX SG



**Pastorfrigor S.p.A.**

Reg. Gabannone, 4 Z.I. · 15033 Terruggia (AL) · Italy  
Tel. +39 0142 433 711 · Fax +39 0142 433 701 · [info@pastorfrigor.it](mailto:info@pastorfrigor.it)  
P.IVA IT00578270068 | REA AL-00578270068  
[www.pastorfrigor.it](http://www.pastorfrigor.it)