

TAP A NEW ENERGY CLASS



CAPRI

Isole

Isola a muro remota per bassa temperatura. L'elevata capacità di carico, la flessibilità intrinseca, consentono un'intelligente utilizzo degli spazi lungo le superfici parietali.



CAPRI BT

CAPRI - Isole

Alimentazione

Remoto

Classi climatiche

3 L1



Colori disponibili

1015

1021

2011

3002

3020

5005

5012

6018

7035

7037

9006

9010

9011

Categorie espositive



Surgelati

Dotazioni di serie

Banco remoto, lineari ed angoli canalizzabili
Batticarrello in ABS grigio
Kit di scarico
Morsettiera
Piano espositivo verniciato bianco
Refrigerazione ventilata
Sbrinamento automatico
Valvola termostatica

Dotazioni opzionali

Batticarrello inox
Chiusure scorrevoli
Coperchi notte
Divisori in griglia
Illuminazione LED
Imballo in gabbia
Quadri comando Master e Slave
Sistema di refrigerazione per Co2
Tende notte manuale
Valvola elettronica
Vetro ultrapanoramico

Dimensioni disponibili

Altezza con spalle (mm) 930
Lunghezza senza spalle (mm) 1875 -2500- 3750
Profondità totale (mm) 1079

ALCUNE FOTO



DISEGNI TECNICI

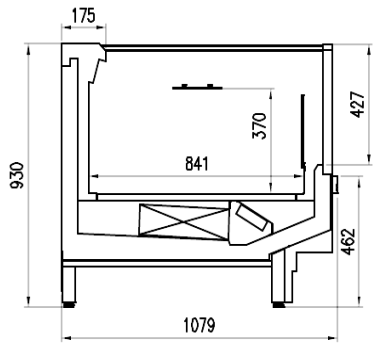

HG



Pastorfrigor S.p.A.

Reg. Gabannone, 4 Z.I. · 15033 Terruggia (AL) · Italy
Tel. +39 0142 433 711 · Fax +39 0142 433 701 · info@pastorfrigor.it
P.IVA IT00578270068 | REA AL-00578270068
www.pastorfrigor.it