

# TAP A NEW ENERGY CLASS



# KALIFORNIA Q

## Murali

Espositore murale di profondità ridotta. Modello particolarmente adatto a punti di vendita con limiti di spazio per via delle sue dimensioni, pur consentendo un'ampia capacità espositiva della merce al suo interno.



# KALIFORNIA Q

## Kalifornia Q - Murali

### Alimentazione

Remoto

### Classi climatiche

3 H

3 M1

3 M2



### Colori disponibili

1021

6032

3020

7037

9010

5007

7047

9011

7024

2004

9006

### Categorie espositive



Affettati



Bibite Fresche



Birra e vino



Carne confezionata



Frutta e verdura



Gastronomia



Latticini, latte,  
formaggio



Piatti pronti ed  
insalate



Snack e panini

### Dotazioni di serie

5 File di ripiani con portaprezzo + base  
Controllore elettronico  
Illuminazione superiore T5  
Refrigerazione ventilata  
Termometro Digitale  
Valvola termostatica

### Dotazioni opzionali

Colori RAL opzionali interni/esterni  
Divisori fissi e mobili  
Illuminazione LED  
Illuminazione ripiani T5/LED  
Sistema di refrigerazione per Co2  
Tenda notte manuale o elettrica  
Valvola elettronica

# ALCUNE FOTO

---

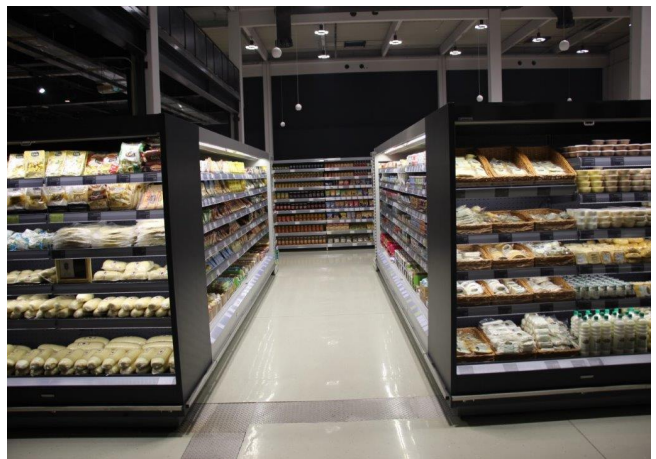

# DISEGNI TECNICI

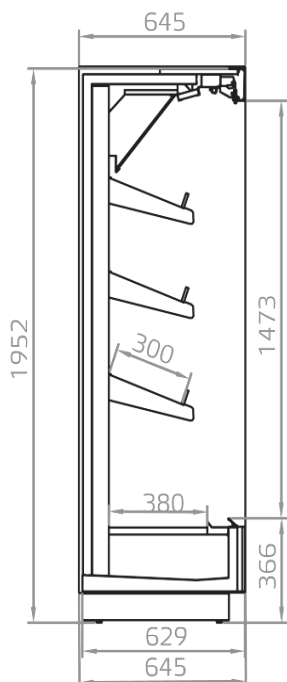

KALIFORNIA Q 300/1950 H

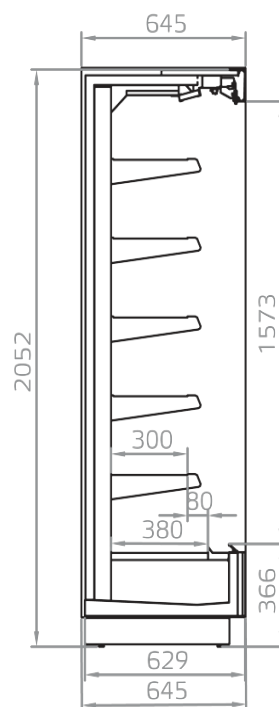

KALIFORNIA Q 300/2050 M1,M2

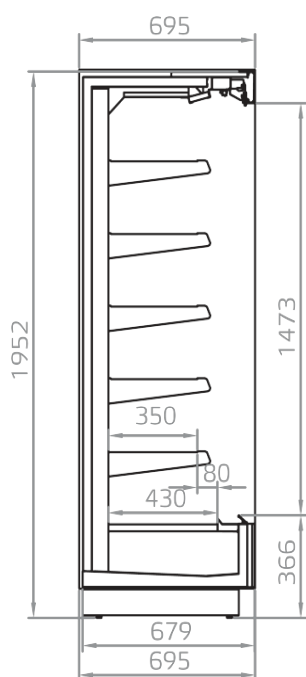

KALIFORNIA Q 350/1950 M1,M2

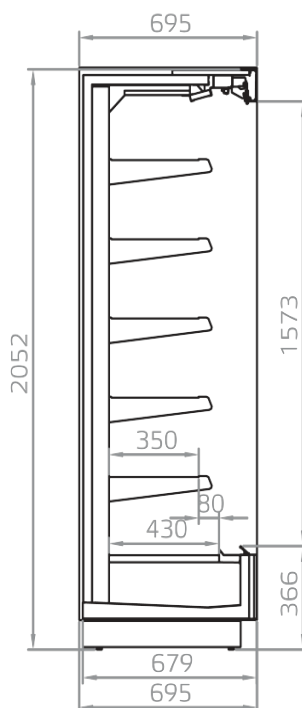

KALIFORNIA Q 350/2050 M1,M2

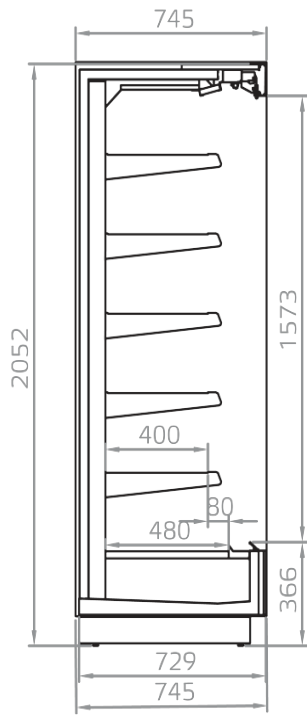

KALIFORNIA Q 400/2050 M1,M2

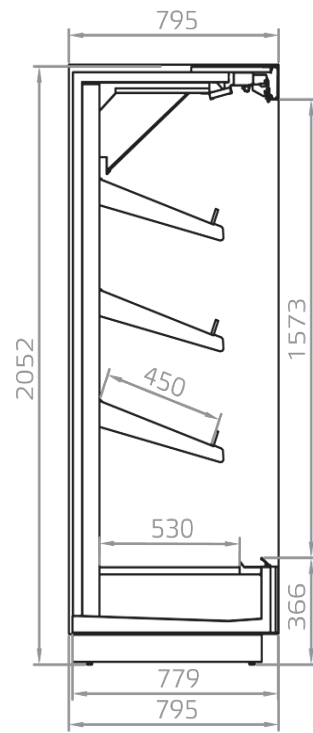

KALIFORNIA Q 450/2050 H

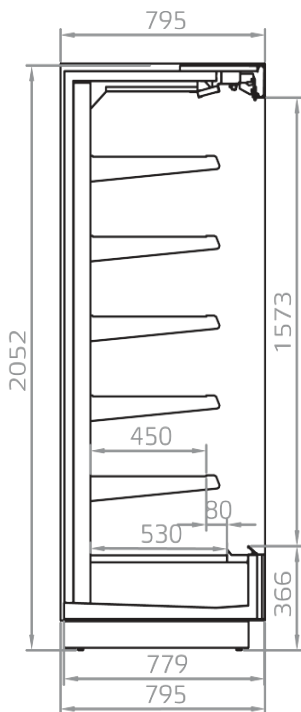

KALIFORNIA Q 450/2050 M1,M2



**Pastorfrigor S.p.A.**

Reg. Gabannone, 4 Z.I. · 15033 Terruggia (AL) · Italy  
Tel. +39 0142 433 711 · Fax +39 0142 433 701 · [info@pastorfrigor.it](mailto:info@pastorfrigor.it)  
P.IVA IT00578270068 | REA AL-00578270068  
[www.pastorfrigor.it](http://www.pastorfrigor.it)